

### Geometry A Practice Final Exam

#### Multiple Choice

Identify the choice that best completes the statement or answers the question.

Use the diagram to answer the following question(s).

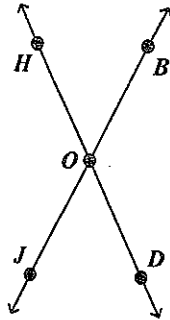

B

1. What is another name for  $\overline{BJ}$ ?

a.  $\overline{OB}$

b.  $\overline{JB}$

c.  $\overline{OJ}$

d.  $\overline{BJ}$

Segments have length.

Therefore,  $\overline{BJ} \cong \overline{JB}$ .

C

2. What is another name for  $\overrightarrow{BJ}$ ?

a.  $\overrightarrow{OB}$

b.  $\overrightarrow{JB}$

c.  $\overrightarrow{BO}$

d.  $\overrightarrow{JO}$

A ray "begins" at an endpoint and extends infinitely in one direction. Therefore,  $\overrightarrow{BJ}$  and  $\overrightarrow{BO}$

are the same ray.

A

3. The figure below is a rectangular shipping box. Name two different planes that contain  $\overleftrightarrow{DH}$ .

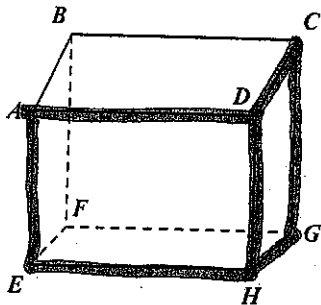

a. plane ADE, plane CGH

b. plane ADE, plane FBC

c. plane ADC, plane CGH

d. plane FBC, plane ADC

$\overleftrightarrow{DH}$  is the side of the front of the box and the side of the right side of the box. Remember, the intersection of two planes is a line. It takes three points to name a plane.

Name: \_\_\_\_\_

ID: A

A 4. Find  $AB$ .

$$AB = x$$

$$AC = 41$$

$$BC = 29$$

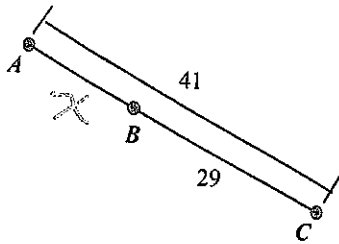

$$AB + BC = AC$$

$$x + 29 = 41$$

$$\begin{array}{r} -29 \\ -29 \end{array}$$

$$x = 12$$

- a. 12
- b. 53

- c. 20.5
- d. 70

B 5. Identify the segment bisector of  $\overline{AB}$ . Then find  $AB$ .

Notice the congruency marks.  $M$  is the bisector/midpoint of  $\overline{AB}$ .

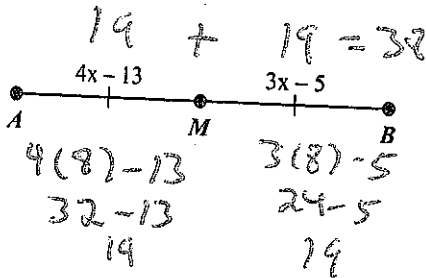

$$\overline{AM} \cong \overline{BM}$$

$$4x - 13 = 3x - 5$$

$$\begin{array}{r} +13 \\ +13 \end{array}$$

$$4x = 3x + 8$$

$$\begin{array}{r} -3x \\ -3x \end{array}$$

$$x = 8$$

- a. line  $M$ ;  $AB = 38$
- b.  $M$ ;  $AB = 38$

- c. line  $M$ ;  $AB = 19$
- d.  $M$ ;  $AB = 19$

D 6. The endpoints of  $\overline{GH}$  are  $G(-3, 0)$  and  $H(7, -8)$ . Find the coordinates of the midpoint  $M$ .

- a.  $(-5, 4)$
- b.  $(-10, 8)$

- c.  $(4, -8)$
- d.  $(2, -4)$

$$M = \left( \frac{x_1 + x_2}{2}, \frac{y_1 + y_2}{2} \right) = \left( \frac{-3 + 7}{2}, \frac{0 + (-8)}{2} \right)$$

$$= (2, -4)$$

A 7. Find the perimeter and area of the polygon with vertices  $A(-1, 5)$ ,  $B(-1, -4)$ ,  $C(-6, -4)$ , and  $D(-6, 5)$ .

- a. Perimeter = 28 units  
Area = 45 units<sup>2</sup>
- b. Perimeter = 18 units  
Area = 81 units<sup>2</sup>

- c. Perimeter = 14 units  
Area = 42 units<sup>2</sup>
- d. Perimeter = 26 units  
Area = 36 units<sup>2</sup>

$$P = 5 + 5 + 9 + 9 = 28$$

$$A = 5(9) = 45$$

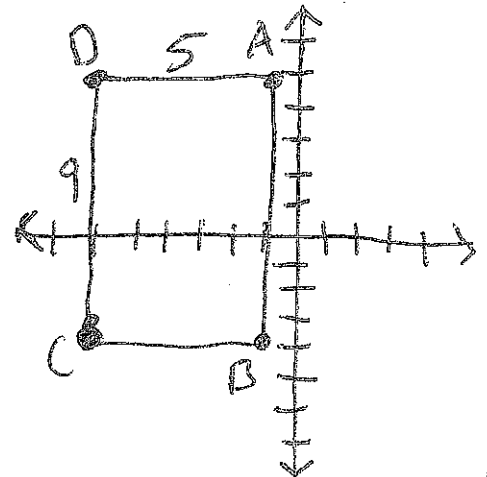

B

8. In the diagram,  $m\angle BDA = 144^\circ$ . Find  $m\angle ADC$ .

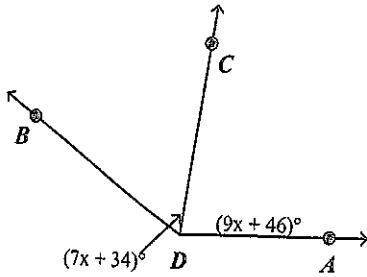

Angle Addition Postulate  
 $m\angle BDC + m\angle CDA = m\angle BDA$

$$\begin{array}{r} 7x + 34 + 9x + 46 = 144 \\ 16x + 80 = 144 \\ -80 \quad -80 \\ \hline 16x = 64 \\ \hline 16 \quad 16 \\ \hline x = 4 \end{array}$$

$$\begin{array}{r} m\angle ADC \\ 9x + 46 \\ 9(4) + 46 \\ 36 + 46 \\ \hline 82 \end{array}$$

- a.  $91^\circ$
- b.  $82^\circ$
- c.  $62^\circ$
- d.  $40^\circ$

B

9. In the diagram,  $\overrightarrow{RT}$  bisects  $\angle SRQ$ , and  $m\angle QRT = 54^\circ$ . Find  $m\angle SRQ$ .

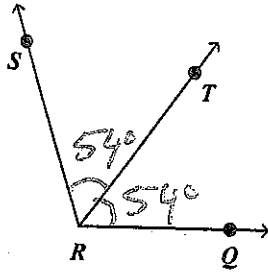

Bisect means to divide in half.  
 Therefore  $\angle SRT \cong \angle QRT$ . By angle addition,  $m\angle SRT + m\angle QRT = m\angle SRQ$ .

$$\begin{array}{r} 54 + 54 = m\angle SRQ \\ 108 = m\angle SRQ \end{array}$$

- a.  $36^\circ$
- b.  $108^\circ$
- c.  $54^\circ$
- d.  $72^\circ$

C 10. In the diagram,  $\overrightarrow{DC}$  bisects  $\angle BDA$ . Find  $m\angle ADC$ . Same as #9 - Bisect

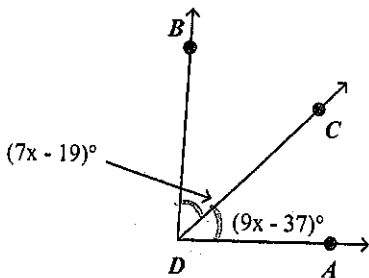

$$\begin{array}{r} 7x - 19 = 9x - 37 \\ -7x \quad -7x \\ -19 = 2x - 37 \\ +37 \quad +37 \\ \hline 18 = 2x \\ \hline \frac{18}{2} = \frac{2x}{2} \\ 9 = x \end{array}$$

$$\begin{array}{r} m\angle ADC \\ 9x - 37 \\ 9(9) - 37 \\ 81 - 37 \\ \hline 44 \end{array}$$

- a.  $28^\circ$
  - b.  $88^\circ$
  - c.  $44^\circ$
  - d.  $22^\circ$
11.  $m\angle 1 = 73^\circ$ . Find the complement and the supplement of  $\angle 1$ .
- a. Complement =  $90^\circ$ , Supplement =  $180^\circ$
  - b. Complement =  $27^\circ$ , Supplement =  $117^\circ$
  - c. Complement =  $17^\circ$ , Supplement =  $107^\circ$
  - d. Complement =  $73^\circ$ , Supplement =  $80^\circ$

Complements add to  $90^\circ$   
 Supplements add to  $180^\circ$

$$\begin{array}{r} 90 \\ -73 \\ \hline 17 \end{array}$$

$$\begin{array}{r} 180 \\ -73 \\ \hline 107 \end{array}$$

*Linear pair adds to 180°*

C 12. Two angles form a linear pair. The measure of one angle is eight times the measure of the other angle. Find the measure of the larger angle.

- a.  $78.8^\circ$
- b.  $157.5^\circ$

- c.  $160^\circ$
- d.  $80^\circ$



$$\begin{aligned} x + 8x &= 180 & 170 \\ 9x &= 180 & -20 \\ x &= 20 & \hline & 160 \end{aligned}$$

A 13. Based on the diagram below, is  $m\angle 2 + m\angle 3 = 180^\circ$ ? If so, state the reason that proves it.

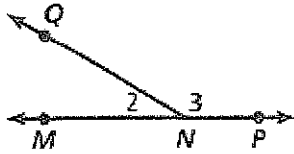

- a. True; They are a linear pair.
- b. True; They are vertical angles.
- c. True; They are adjacent angles.
- d. False

B 14. Find the values of  $x$  and  $y$ . *This problem is based on vertical angles.*

*Vertical angles are  $\cong$ .*

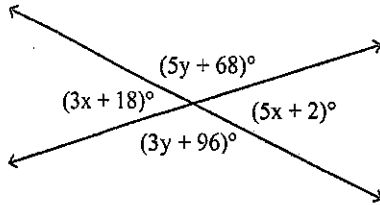

$$\begin{aligned} 3x + 18 &= 5x + 2 \\ -2 & \quad -2 \end{aligned}$$

$$\begin{aligned} 3x + 16 &= 5x \\ -3x & \quad -3x \end{aligned}$$

$$\begin{aligned} 16 &= 2x \\ 8 &= x \end{aligned}$$

- c.  $x = 20, y = 14$
- d.  $x = 8, y = 2$

$$5y + 68 = 3y + 96$$

$$-68 \quad -68$$

$$5y = 3y + 28$$

$$\begin{aligned} -3y & \quad -3y \end{aligned}$$

$$2y = 28$$

$$y = 14$$

a.  $x = 20, y = 2$

b.  $x = 8, y = 14$

D 15. In the diagram,  $c \parallel d$ . Identify three numbered angles that have a measure of  $105^\circ$ .

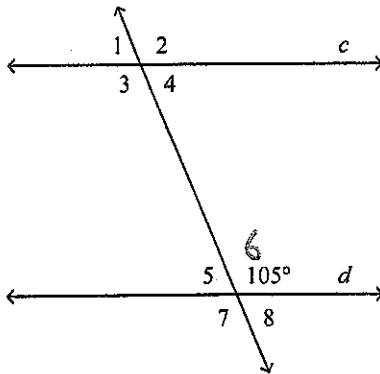

$$\angle 1 \cong \angle 4 \cong \angle 5 \cong \angle 8$$

$$\angle 2 \cong \angle 3 \cong \angle 6 \cong \angle 7 \rightarrow 105^\circ$$

*See p. 132 Textbook*

*or*

*p. 73-74 Journal*

- a.  $\angle 2, \angle 7,$  and  $\angle 1$
- b.  $\angle 3, \angle 7,$  and  $\angle 4$

- c.  $\angle 2, \angle 4,$  and  $\angle 1$
- d.  $\angle 2, \angle 3,$  and  $\angle 7$

Name: \_\_\_\_\_

ID: A

B 16. In the diagram,  $a \parallel b$ . Find the value of  $x$ .

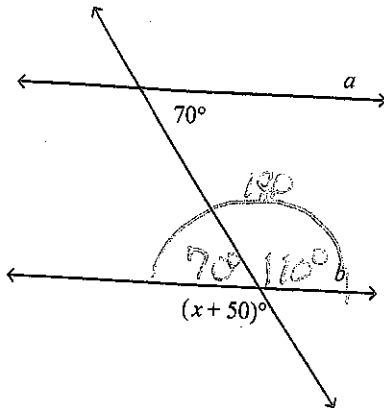

$$\begin{aligned} x + 50 &= 110 \\ -50 &\quad -50 \\ \hline x &= 60 \end{aligned}$$

- a. 120
- b. 60
- c. 20
- d. 160

A 17. In the diagram,  $\overleftrightarrow{BC}$  bisects  $\angle ACD$  and  $j \parallel k$ . Find the value of  $w$ .

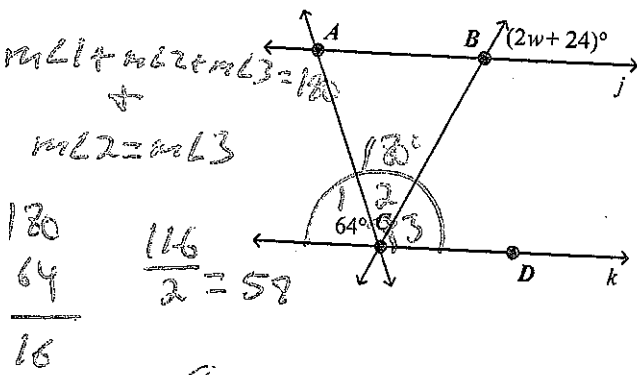

$(2w + 24)^\circ + \angle 3$  are corresponding angles.  
 Corresponding angles are congruent.  
 $2w + 24 = 58$   
 $-24 \quad -24$   
 $\frac{2w}{2} = \frac{34}{2}$   
 $w = 17$

- a. 17
- b. 4
- c. 28
- d. 41

D 18. Find the distance from point  $P$  to  $\overline{RQ}$ .

The shortest distance from a point to a line is along a perpendicular ( $90^\circ$ ) path.

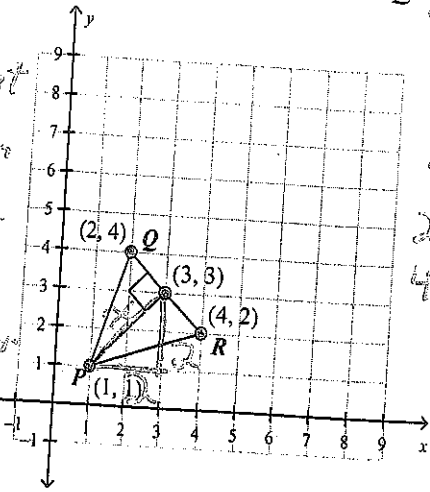

Method 1



Pythagorean Theorem  
 $a^2 + b^2 = c^2$   
 $2^2 + 2^2 = x^2$   
 $4 + 4 = x^2$   
 $8 = x^2$   
 $\sqrt{8} = \sqrt{x^2}$   
 $2.8 = x$

Method 2

Distance Formula

$$d = \sqrt{(x_2 - x_1)^2 + (y_2 - y_1)^2}$$

$(1, 1), (3, 3)$

$$d = \sqrt{(3-1)^2 + (3-1)^2}$$

$$d = \sqrt{(2)^2 + (2)^2}$$

$$d = \sqrt{4 + 4}$$

$$d = \sqrt{8}$$

$$d = 2.8$$

- a. about 3.2 units
- b. 4 units
- c. 10 units
- d. about 2.8 units

D 19. Write an equation of the line passing through the point  $(6, -2)$  that is parallel to the line  $y = 4x - 11$ .

a.  $y = -\frac{1}{4}x - 2$   $y = mx + b$

b.  $y = -\frac{1}{4}x - 26$   $m = 4$  slope

c.  $y = 4x - 2$   $y - y_1 = m(x - x_1)$   $y = 4x - 26$

d.  $y = 4x - 26$   $y - (-2) = 4(x - 6)$   
 $y + 2 = 4x - 24$

B 20. Write an equation of the line passing through the point  $(6, 4)$  that is perpendicular to the line  $y = -\frac{1}{5}x - 7$ .

a.  $y = -5x + 34$   $m = -\frac{1}{5}$  opposite

b.  $y = 5x - 26$   $\perp m = 5$  reciprocal

c.  $y = -\frac{1}{5}x + \frac{26}{5}$   $y - y_1 = m(x - x_1)$   $y = 5x - 26$

d.  $y = \frac{1}{5}x + \frac{14}{5}$   $y - 4 = 5(x - 6)$   
 $y - 4 = 5x - 30$   
 $+4$   $+4$

B 21. An architect is designing a garden for a client on a planning sheet. The client requests the relocation of a water fountain by the rule  $(x, y) \rightarrow (x+9, y-7)$ . Later, the client decides that they would prefer the water fountain's location moved from this new position 5 units left and 2 units up. Find the composition as a single transformation.

- a.  $(x, y) \rightarrow (x+2, y-5)$
- b.  $(x, y) \rightarrow (x+4, y-5)$
- c.  $(x, y) \rightarrow (x+11, y-12)$
- d.  $(x, y) \rightarrow (x+14, y-9)$

$$\begin{array}{r}
 (x+9, y-7) \\
 + \\
 (x-5, y+2) \\
 \hline
 (x+4, y-5)
 \end{array}$$

9 right, 7 down followed by 5 left, 2 up.

Name: \_\_\_\_\_

ID: A

22. Graph  $\triangle BCD$  with vertices  $B(2, 1)$ ,  $C(3, 3)$  and  $D(3, 1)$  and its image after the reflection in the line  $n: x = 4$ .

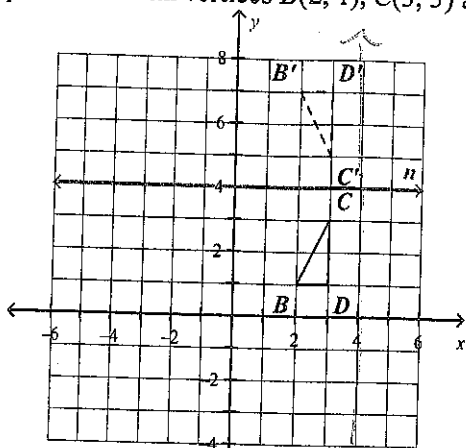

a.

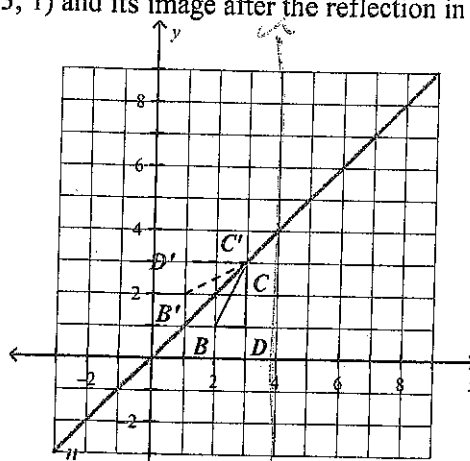

c.

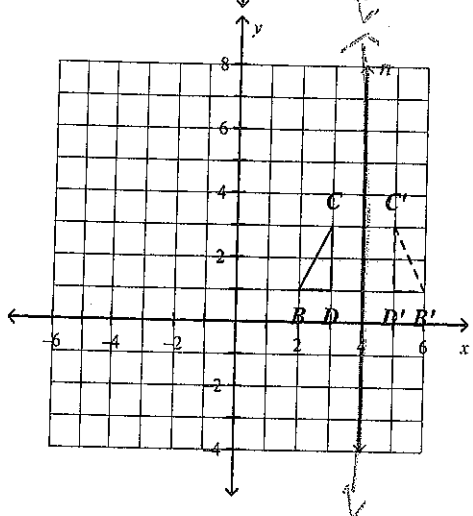

b.

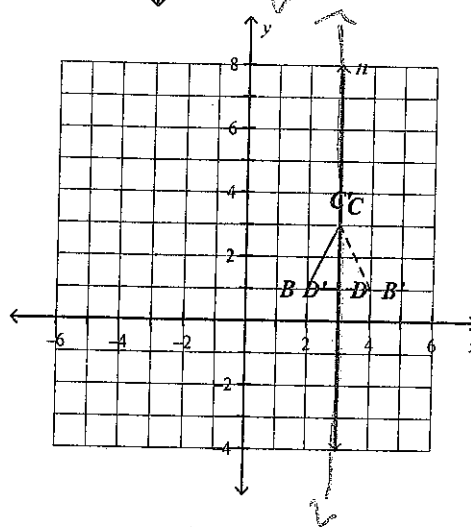

d.

$\triangle BCD$  and  $\triangle B'C'D'$  are equidistant from  $n: x = 4$ .

23. Graph  $\overline{AB}$  with endpoints  $A(2, -2)$  and  $B(2, 1)$  and its image after a reflection in the line  $y = x$ .

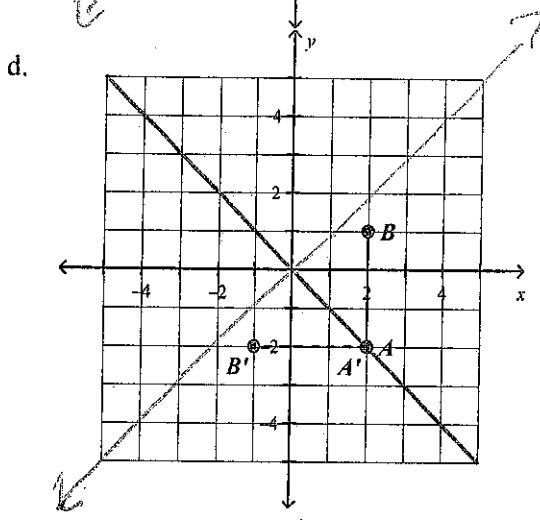
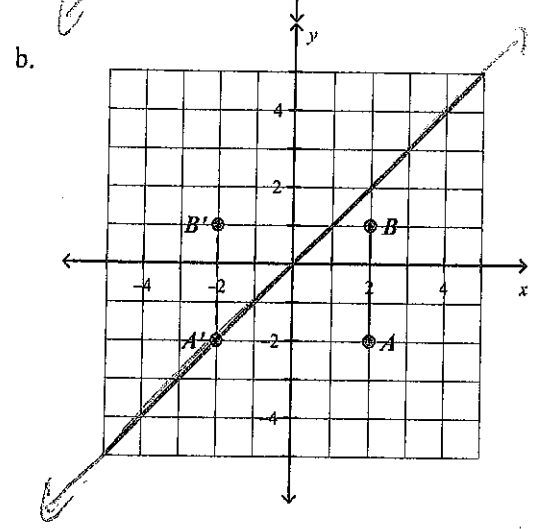
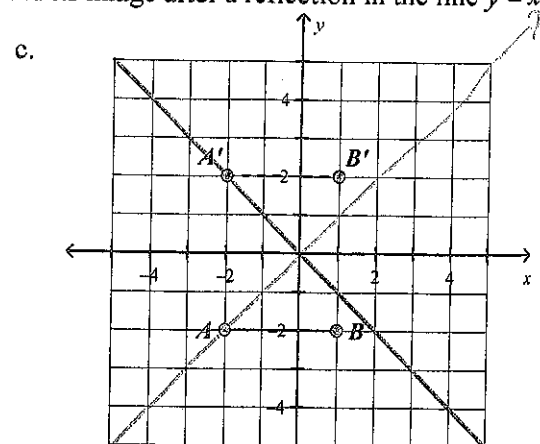
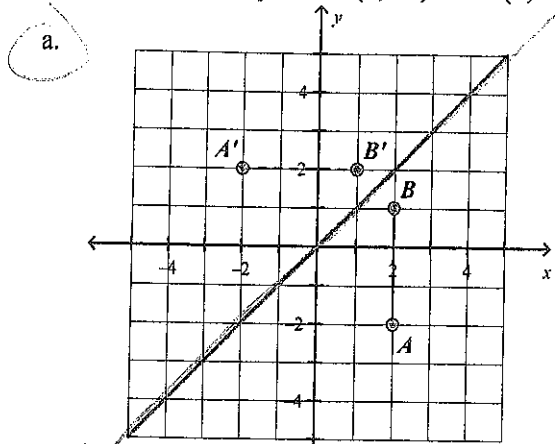

$y = x$  reflection.  
 $(a, b) \rightarrow (b, a)$   
 $A(2, -2) \rightarrow A'(-2, 2)$   
 $B(2, 1) \rightarrow B'(1, 2)$



24. Graph  $\triangle ABC$  with vertices  $A(-4, 0)$ ,  $B(-3, 2)$  and  $C(-1, 2)$  and its image after the glide reflection.

Translation:  $(x, y) \rightarrow (x+2, y)$

Reflection: in the  $x$ -axis  $\rightarrow (a, b) \rightarrow (a, -b)$

a.

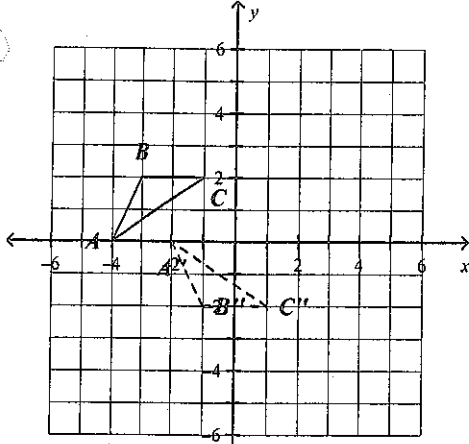

c.

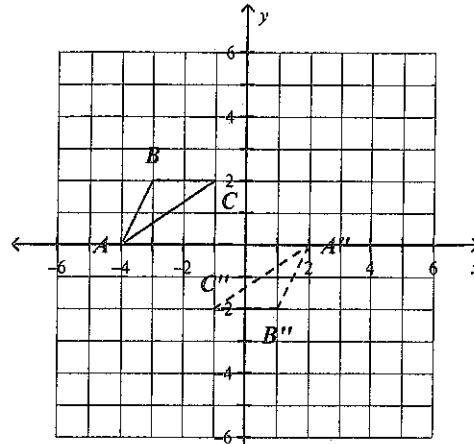

b.

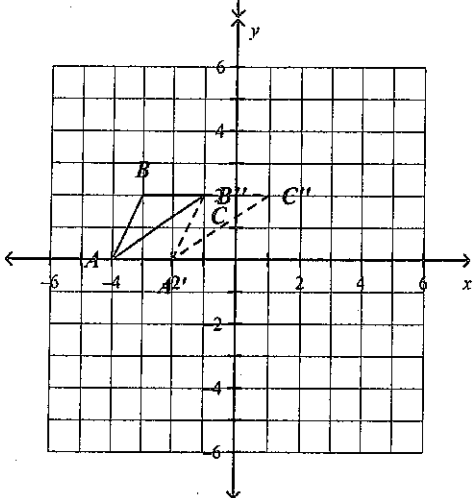

d.

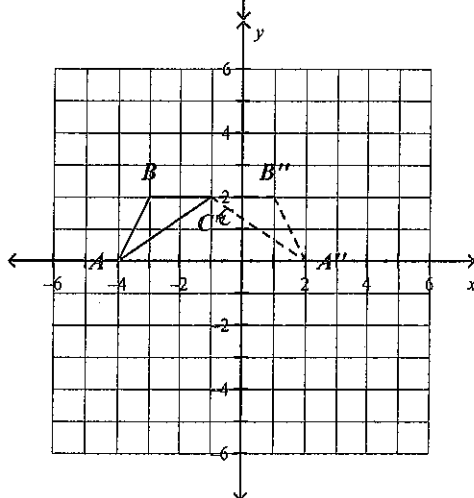

$$\begin{aligned}
 A(-4, 0) &\xrightarrow{(x+2, y)} A'(-2, 0) \xrightarrow{(a, b) \rightarrow (a, -b)} A''(-2, 0) \\
 B(-3, 2) &\longrightarrow B'(-1, 2) \longrightarrow B''(-1, -2) \\
 C(-1, 2) &\longrightarrow C'(1, 2) \longrightarrow C''(1, -2)
 \end{aligned}$$



25. Graph polygon  $ABCD$  with vertices  $A(4, -6)$ ,  $B(3, -3)$ ,  $C(2, -4)$  and  $D(2, -6)$ . Then, graph its image after a rotation of  $90^\circ$  counterclockwise about the origin.

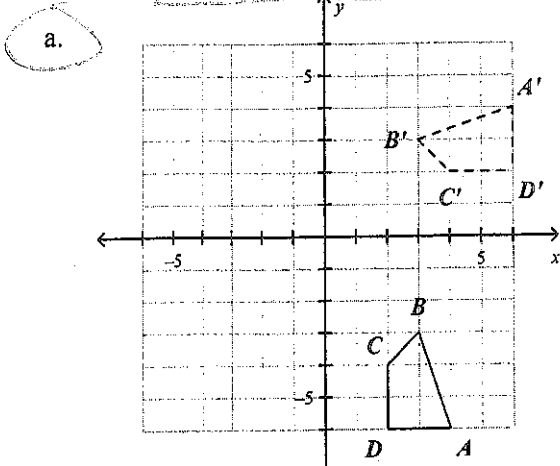

c.

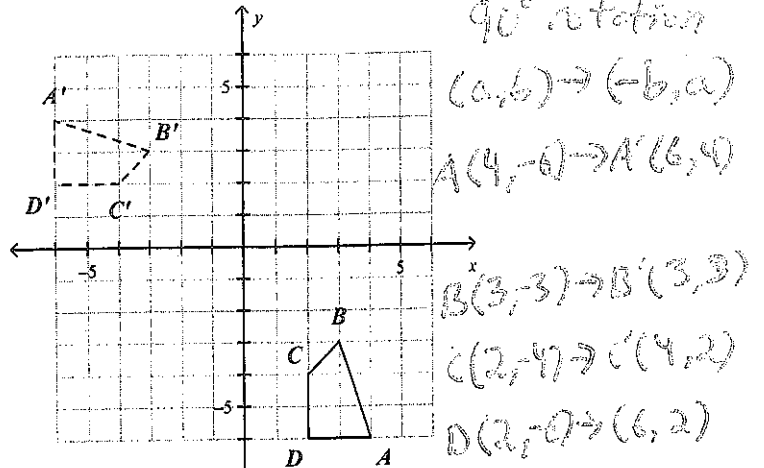

b.

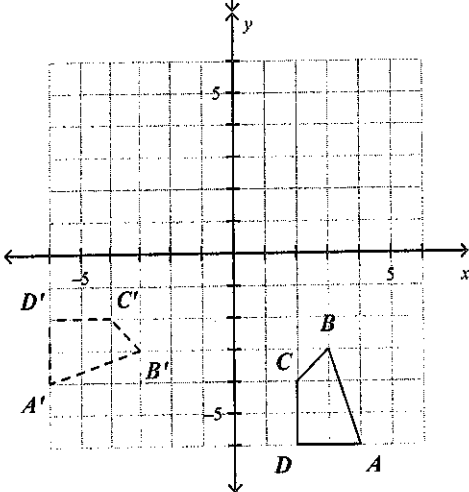

d.

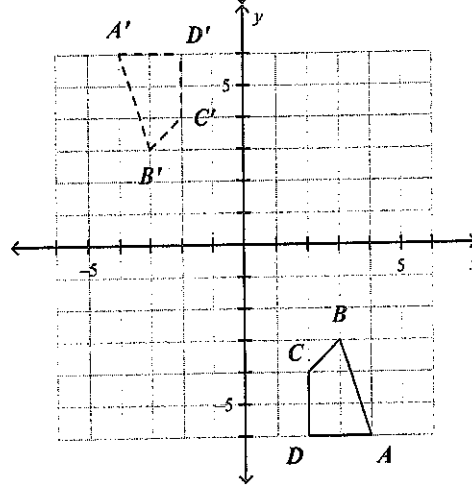

26. Find the scale factor of the dilation. Then tell whether the dilation is a *reduction* or an *enlargement*.

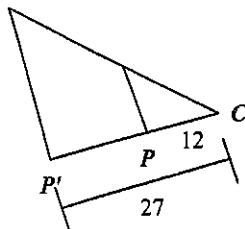

scale factor =  $k$

$$k = \frac{P'}{P} = \frac{27}{12} = \frac{9}{4}$$

a.  $\frac{4}{9}$ ; reduction

b.  $\frac{4}{5}$ ; reduction

c.  $\frac{9}{4}$ ; enlargement

d.  $\frac{5}{4}$ ; enlargement

Name: \_\_\_\_\_

27. Find the value of  $x$ .

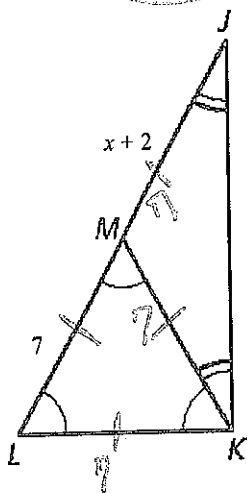

$\triangle MLK$  is equilateral because all 3 angles are marked congruent.  
 $\triangle MKJ$  is isosceles because 2 angles are congruent.

$$\begin{aligned} x+2 &= 7 \\ -2 &-2 \\ x &= 5 \end{aligned}$$

- a. 7
- b. 9
- c. 14
- d. 5

28. Find  $m\angle M$ .

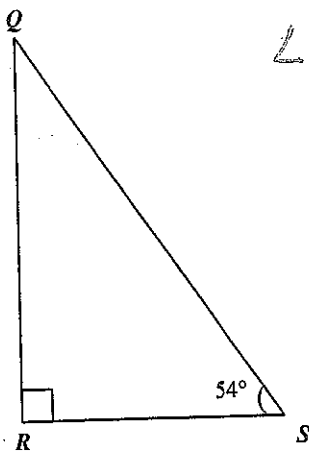
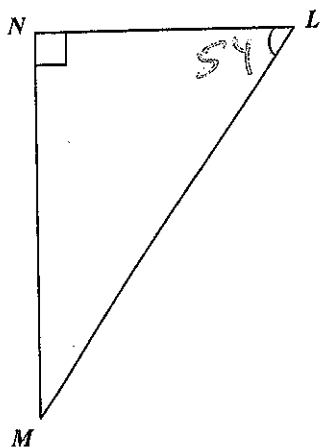

$$\angle S \cong \angle L$$

$$\begin{array}{r} 180 \\ - 90 \\ - 54 \\ \hline 36 \end{array}$$

- a.  $54^\circ$
- b.  $27^\circ$
- c.  $63^\circ$
- d.  $36^\circ$

Name: \_\_\_\_\_

ID: A

D 29. Find  $m\angle KMN$ . Exterior Angles

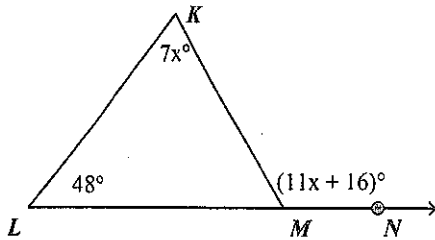
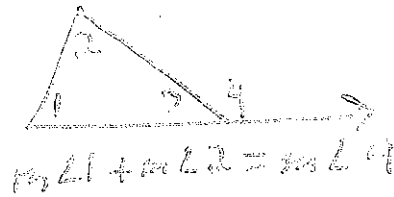

$$7x + 48 = 11x + 16$$

$$\quad -16 \quad \quad -16$$

$$7x + 32 = 11x$$

$$\quad -7x \quad \quad -7x$$

$$32 = 4x$$

$$\frac{32}{4} = \frac{4x}{4}$$

$$8 = x$$

$m\angle KMN$

$$11x + 16$$

$$11(8) + 16$$

$$88 + 16$$

$$104$$

- a.  $56^\circ$
- b.  $76^\circ$

- c.  $8^\circ$
- d.  $104^\circ$

B 30. In the diagram,  $\triangle CDE \cong \triangle GHI$ . Find the value of  $y$ .

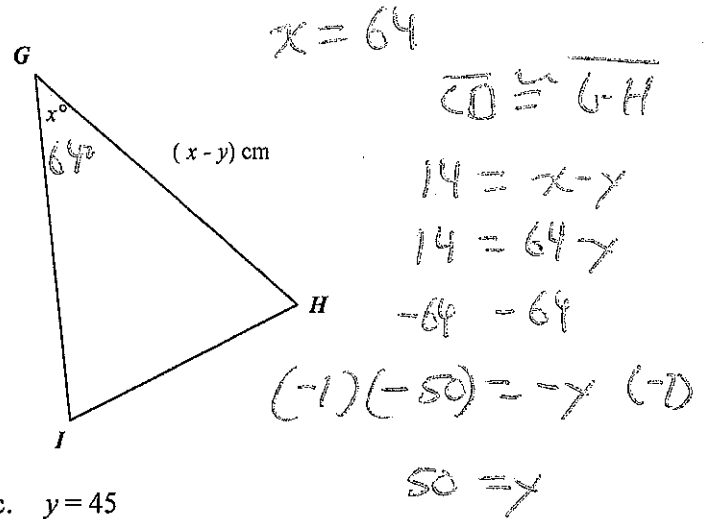
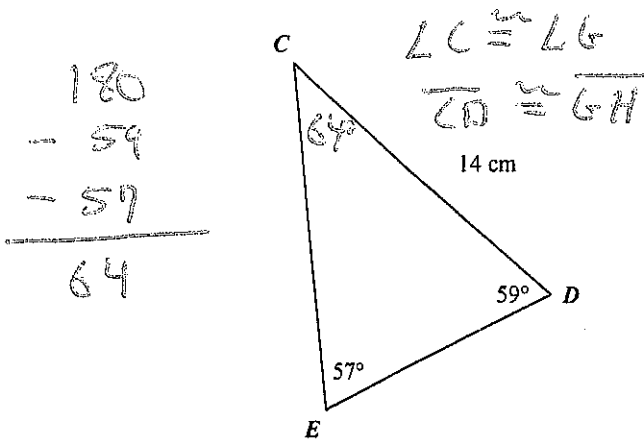

- a.  $y = 43$
- b.  $y = 50$

- c.  $y = 45$
- d.  $y = 78$

Name: \_\_\_\_\_

ID: A

31. Find  $m\angle BDC$ .

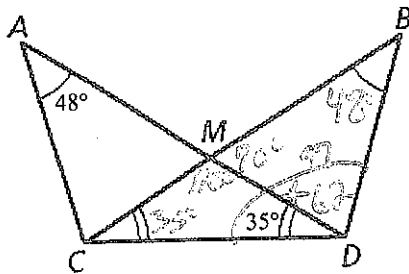

- a.  $70^\circ$
- b.  $97^\circ$

- c.  $62^\circ$
- d.  $83^\circ$

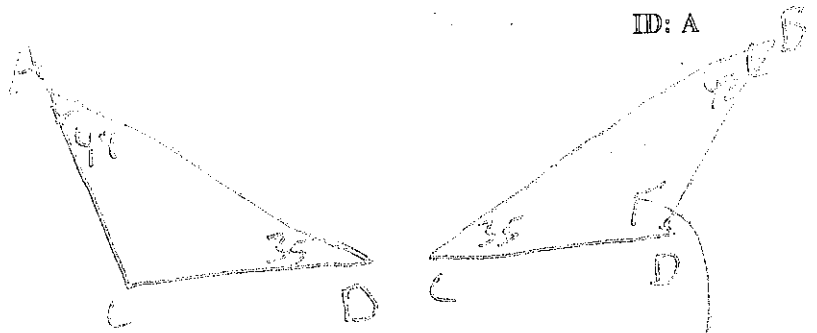

$$\begin{array}{r} 180 \\ - 48 \\ - 35 \\ \hline 97 \end{array}$$

32. In the diagram, name the vector and select its component form.

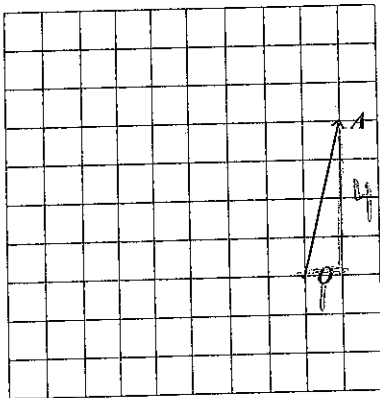

Vectors have an initial point and a terminal point. When naming a vector, state the initial point (where it begins) first and the terminal point (where it ends - by the arrow) second. This is vector  $\vec{OA}$ .

- a.  $\vec{AO}, \langle -4, -1 \rangle$
- b.  $\vec{OA}, \langle 4, 1 \rangle$
- c.  $\vec{AO}, \langle -1, -4 \rangle$
- d.  $\vec{OA}, \langle 1, 4 \rangle$

Component form is the distance traveled on the x-axis (left/right) followed by the distance traveled on the y-axis (up/down). Do not count component form like you count slope.

$$\vec{OA} \langle 1, 4 \rangle$$

D 33.  $\overline{AX}$  and  $\overline{YB}$  bisect each other at point  $M$ . Which theorem can be used to prove  $\triangle ABM \cong \triangle XYM$ ?

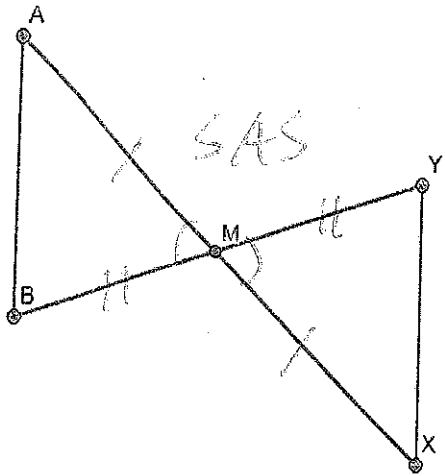

It is stated that  $\overline{AX}$  and  $\overline{YB}$  bisect each other at point  $M$ . Therefore,  $M$  is the midpoint of  $\overline{AX}$  and the midpoint of  $\overline{YB}$ .

$\overline{AM} \cong \overline{XM}$   
 $\overline{BM} \cong \overline{YM}$   
 $\angle AMB \cong \angle XMY$  vertical angles

- a. SSS                      b. AAS                      c. ASA                      **d. SAS**

A 34.  $\overline{BD}$  bisects  $\angle ADC$  and  $\overline{DB}$  bisects  $\angle ABC$ . Which theorem can be used to prove  $\triangle ADB \cong \triangle CDB$ ?

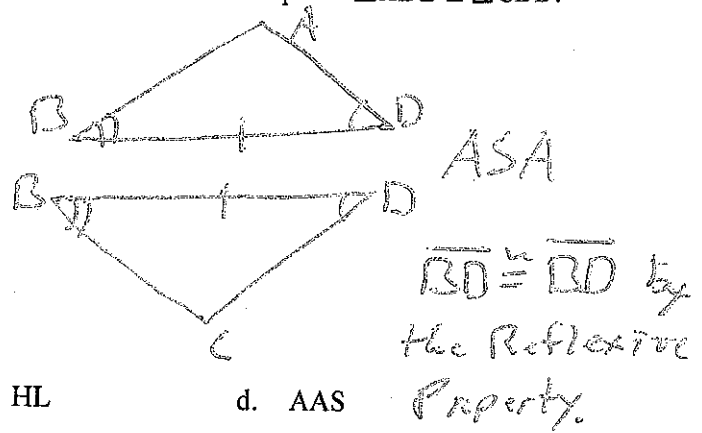
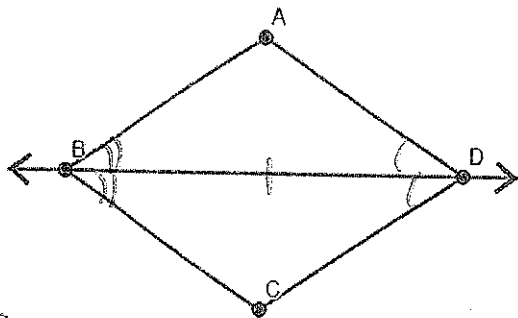

- a. ASA**                      b. SAS                      c. HL                      d. AAS

A 35. Which theorem can be used to prove  $\triangle JIH \cong \triangle HKJ$ ?

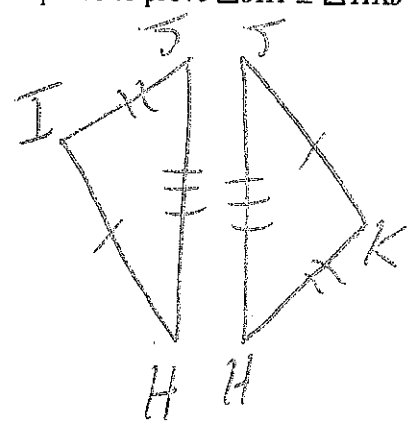
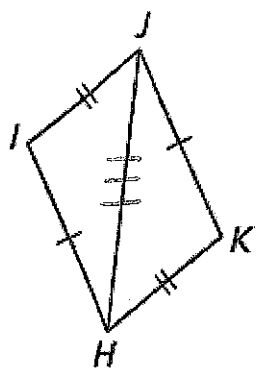

- a. SSS                      b. SAS                      c. ASA                      d. Cannot be determined.

36. Which reason is not necessary to explain how you can find the distance across the lake?

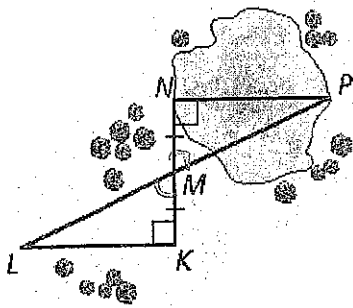

$\overline{NM} \cong \overline{KM}$  Given  
 $\angle N \cong \angle K$  Right Angles  
 $\angle NMP \cong \angle KML$  Vertical Angles  
 $\triangle NMP \cong \triangle KML$  ASA  
 $\overline{LN} \cong \overline{PK}$  CPCTC

- a. ASA Congruence Theorem
- b. Right Angles Congruence Theorem
- c. SSS Congruence Theorem
- d. Corresponding parts of congruent triangles are congruent. CPCTC
- e. Vertical Angles Congruence Theorem

37. Find AC.

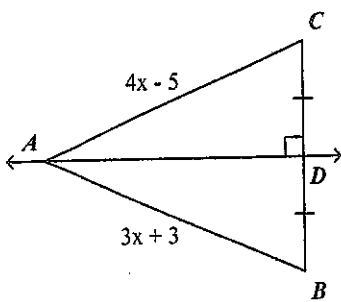

$\overline{CD} \cong \overline{BD}$  and  $\overline{AD} \perp \overline{BC}$ . Therefore,  $\overline{AD}$  is a perpendicular bisector. By rule, points on a  $\perp$  bisector are equidistant from the endpoints of the bisected segment. Therefore,  $\overline{AC} \cong \overline{AB}$ .

- a. AC = 27
- b. AC = 8

- c. AC = 26
- d. AC = 13

$$\begin{aligned}
 4x - 5 &= 3x + 3 \\
 -3x &\quad -3x \\
 x - 5 &= 3 \\
 +5 &\quad +5 \\
 x &= 8
 \end{aligned}$$

$$\begin{aligned}
 &AC \\
 &4x - 5 \\
 &4(8) - 5 \\
 &32 - 5 \\
 &27
 \end{aligned}$$

Name: \_\_\_\_\_

38. Find the coordinates of the circumcenter of  $\triangle ABC$  with vertices  $A(7,-8)$ ,  $B(5,-2)$ , and  $C(1,-2)$ .

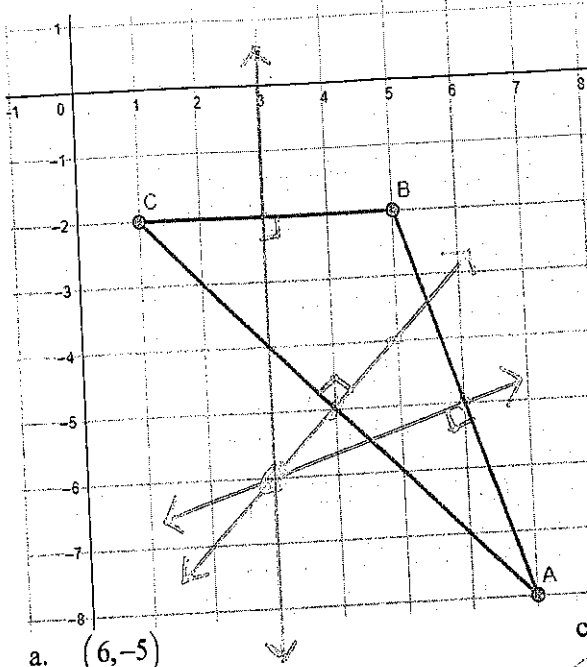

The circumcenter is found by drawing the  $\perp$  bisectors of all 3 sides of a triangle.  
 Find the midpoint and slope of the sides.

$\overline{AB}$	$\overline{AC}$	$\overline{CB}$
$m = -\frac{6}{2} = -3$	$m = -\frac{6}{6} = -1$	$m = 0$ (horizontal)
$\perp m = \frac{1}{3}$	$\perp m = 1$	$\perp m =$ undefined (vertical)

- a.  $(6,-5)$
- b.  $(4,-5)$

- c.  $(3,-3.9)$
- d.  $(3,-6)$

The point of concurrency is  $(3,-6)$  so that is the circumcenter.

39. In  $\triangle LMN$ , point  $P$  is the centroid, and  $BP = 3$ . Find  $LP$  and  $BL$ .

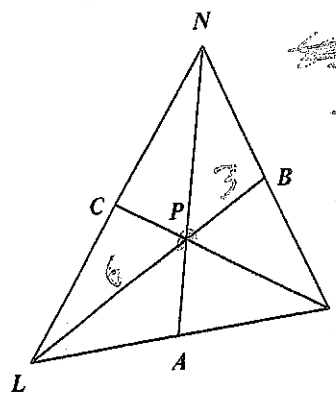

The centroid is found by drawing the medians of a triangle. By rule, the "long part" of the median is double the "short part." That means the "long part" of the median is  $\frac{2}{3}$  the entire length of the median.

- a.  $LP = 3, BL = 6$
- b.  $LP = 1.5, BL = 4.5$
- c.  $LP = 9, BL = 12$
- d.  $LP = 6, BL = 9$

$LP = 3(2) = 6$   
 $BL = 3 + 6 = 9$



Name: \_\_\_\_\_

40. In  $\triangle ABC$ ,  $N$  is the incenter,  $ND = 9x + 3$ , and  $NF = 8x + 6$ . Find  $NE$ .

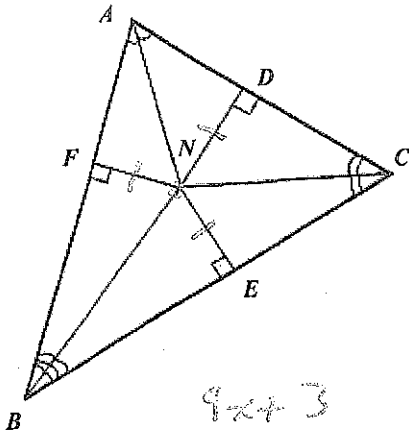

The incenter is formed by drawing the angle bisectors of a triangle. The point where the 3 angle bisectors meet is the incenter. The incenter is equidistant from the 3 sides of the triangle. Therefore,  $\overline{ND} \cong \overline{NF} \cong \overline{NE}$ .

- a.  $NE = 3$
- b.  $NE = 60$

$$9x + 3 = 8x + 6$$

$$9x + 3 = 8x + 6$$

$$27 + 3 = 30$$

- c.  $NE = 24$
- d.  $NE = 30$

$$9x + 3 = 8x + 6$$

$$-8x \quad -8x$$

$$x + 3 = 6$$

$$-3 \quad -3$$

$$x = 3$$

41. Which statement is true based on the diagram?

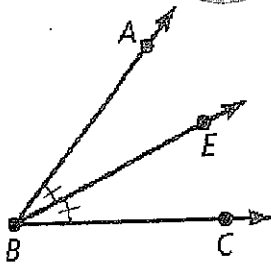

Notice that  $\angle ABE$  is marked congruent to  $\angle EBC$ . That means  $\overrightarrow{BE}$  is bisecting  $\angle ABC$ .

- a.  $\angle ABE$  and  $\angle EBC$  are vertical angles.
- b.  $\overrightarrow{BE}$  is an angle bisector.
- c. Points A, B, and C are collinear.
- d. none of these

42. Which statement is true based on the diagram?

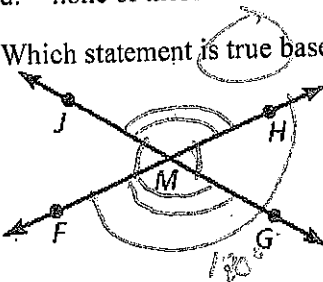

- a.  $\overline{JM}$  and  $\overline{MG}$  are congruent segments.
- b.  $\angle FMG$  and  $\angle HMG$  are a linear pair.
- c.  $\overrightarrow{MJ}$  and  $\overrightarrow{MH}$  are opposite rays.
- d. none of these

Example

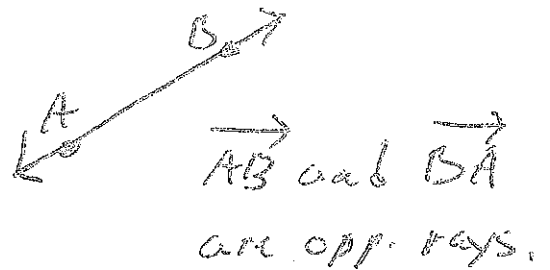

Name: \_\_\_\_\_

43. Which of the following statements is false?

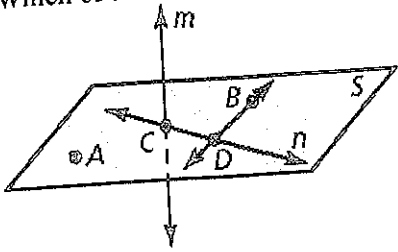

Based on the diagram, A, B, and C are not on the same line.

- a. Line  $n$  and  $\overleftrightarrow{BD}$  intersect at point  $D$ .
- b. Line  $m$  intersects plane  $S$  at point  $C$ .

- c. Points  $A$ ,  $B$ , and  $C$  are collinear.
- d. Line  $n$  is in plane  $S$ .

44. Which of the following statements is false?

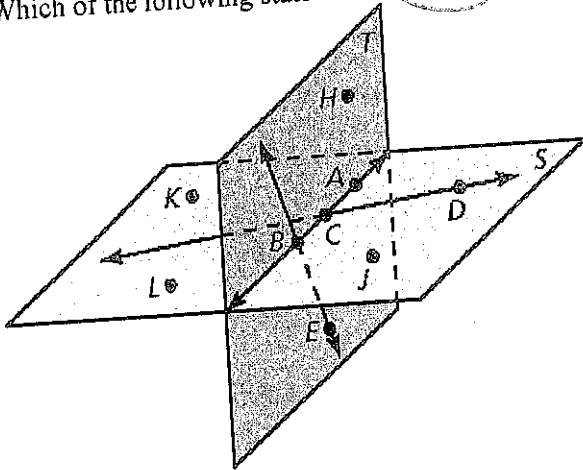

- a.  $\overleftrightarrow{CD}$  and  $\overleftrightarrow{AB}$  are coplanar.
- b. Plane  $T$  and plane  $S$  intersect at  $\overleftrightarrow{AB}$ .
- c. Plane  $S$  contains points  $L$ ,  $B$ , and  $E$ .
- d. Points  $A$ ,  $B$ , and  $C$  all exist in both planes  $S$  and  $T$ .

Point E is only in plane T.

45. In the diagram,  $m\angle 1 = (2x + 4)^\circ$  and  $m\angle 5 = (4x + 20)^\circ$ . What is the measure of  $\angle 2$ ?

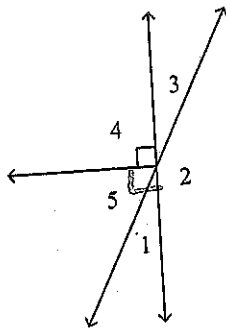

$$\begin{aligned}
 m\angle 1 + m\angle 5 &= 90 \\
 2x + 4 + 4x + 20 &= 90 \\
 6x + 24 &= 90 \\
 -24 \quad -24 & \\
 6x &= 66 \\
 x &= 11
 \end{aligned}$$

$$\begin{aligned}
 m\angle 1 &= 2(11) + 4 = 22 + 4 = 26^\circ \\
 m\angle 5 &= 4(11) + 20 = 44 + 20 = 64^\circ
 \end{aligned}$$

$\angle 1$  &  $\angle 3$  are vertical  $\angle$ s.  
 $\angle 1 \cong \angle 3$   
 $26^\circ = m\angle 3$

$\angle 2$  &  $\angle 3$  are a linear pair.  
 $m\angle 2 + m\angle 3 = 180$   
 $m\angle 2 + 26 = 180$   
 $-26 \quad -26$   
 $m\angle 2 = 154^\circ$

- a.  $26^\circ$
- b.  $64^\circ$

- c.  $154^\circ$
- d.  $178^\circ$

Name: \_\_\_\_\_

Short Answer

46. Determine which of the lines are parallel and which of the lines are perpendicular.

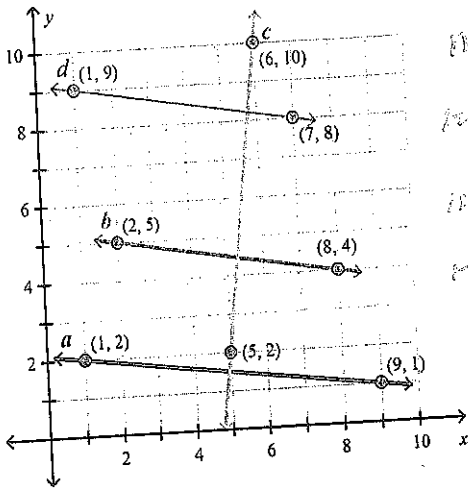

$m_a = -\frac{1}{8}$   
 $m_b = -\frac{1}{8}$   
 $m_c = \frac{8}{1} = 8$   
 $m_d = -\frac{1}{8}$

Find the slope of each line

• // slopes are =  
 •  $\perp$  slopes are opposite reciprocals

~~b and d~~ b and d have the same slope  
 a and c have slopes that are opposite reciprocals

- a.  $a \parallel c, b \perp d$     b.  $a \parallel b, c \perp d$     c.  $b \parallel d, a \perp c$     d.  $a \parallel d, b \perp c$

47. Find the measure of each acute angle.

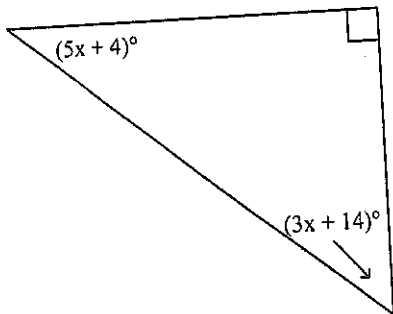

The sum of the measures of a triangle is  $180^\circ$ .

$$5x + 4 + 3x + 14 + 90 = 180$$

$$8x + 108 = 180$$

$$-108 \quad -108$$

$$8x = 72$$

$$\frac{72}{8} \quad \frac{72}{8}$$

$$x = 9$$

- A.  $49^\circ, 41^\circ$     B.  $52^\circ, 38^\circ$     C.  $40^\circ, 50^\circ$     D.  $68^\circ, 22^\circ$

$$5(9) + 4$$

$$45 + 4$$

$$49$$

$$3(9) + 14$$

$$27 + 14$$

$$41$$

Name: \_\_\_\_\_

Problem

A 48.

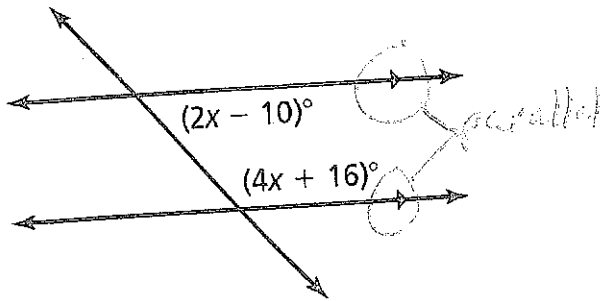

- A.  $x = 29$     B.  $x = -13$     C.  $x = 31$     D.  $x = 13$

These angles are consecutive interior (same-side interior) angles. Therefore, they have a sum of 180. See page 132.

$$2x - 10 + 4x + 16 = 180$$

$$6x + 6 = 180$$

$$-6 \quad -6$$

$$\underline{6x = 174}$$

$$\underline{\quad \quad 6}$$

$$x = 29$$

D 49.

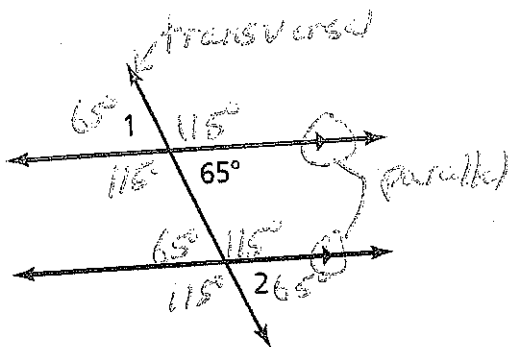

- A.  $m\angle 1 = 65^\circ, m\angle 2 = 115^\circ$     B.  $m\angle 1 = 115^\circ, m\angle 2 = 115^\circ$   
 C.  $m\angle 1 = 115^\circ, m\angle 2 = 115^\circ$     D.  $m\angle 1 = 65^\circ, m\angle 2 = 65^\circ$

When two parallel lines are intersected by a transversal, the angles that are formed are all related in some way.

See p. 132.

- $\angle 1 + 65^\circ$  are vertical  $\angle$ s  
Vertical angles are  $\cong$ .
- $\angle 2 + 65^\circ$  are corresponding  $\angle$ s  
Corresponding angles are  $\cong$ .

50. A search and rescue crew suspect that a ship sank at a location that is equidistant from the three vertices of the Bermuda Triangle. Which statement below states the point of concurrency that the search and rescue crew is looking for and the proper method for locating it?

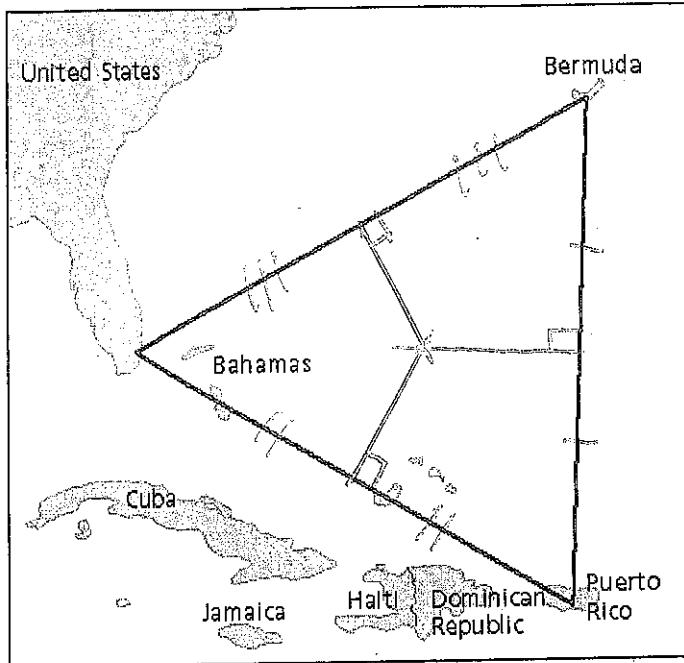

- A. The search and rescue crew is looking for orthocenter. This is found by drawing the three altitudes of a triangle.
- B. The search and rescue crew is looking for the incenter. This is found by drawing the three angle bisectors of a triangle.
- C. The search and rescue crew is looking for the circumcenter. This is found by drawing the three perpendicular bisectors of a triangle.
- D. The search and rescue crew is looking for the centroid. This is found by drawing the three medians of a triangle.

By definition, the circumcenter is equidistant from the three vertices of a triangle. The circumcenter is found by drawing the perpendicular bisectors of each side of the triangle.

See p. 323